

KDS800 INSTRUCTION MANUAL

KDS800 is a gyro with function of dual rate and head lock, which designed for helicopters specially. KDS800 adopts AVCS(Angular Vector Control System), which makes the function of head lock more outstanding and steady.

AVCS system: Since rudder trim changes caused by wind and other meteorological changes, and varieties of helicopter attitude changes are automatically cancelled, tail rudder operation becomes easy, making it perfect for 3D flight.

KDS800 specifications:

Digital proportional R/C system
 Operating voltage: 4.8V ~6V(common for receiver)
 Operating temperature: -10℃~+45℃
 Dimensions: 28×28×20 mm
 Operating current: 80mA

Functions:

- Minimizes changes in an aircraft's attitude by wind etc
- Angular acceleration commands used
- Sensor vibration proofing
- Simple sensitivity adjustment

open the the package of KDS800, you will find the part sets:

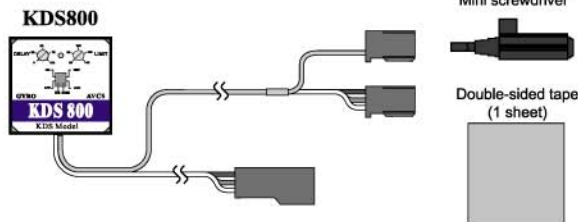

KDS800 Functions explanation:

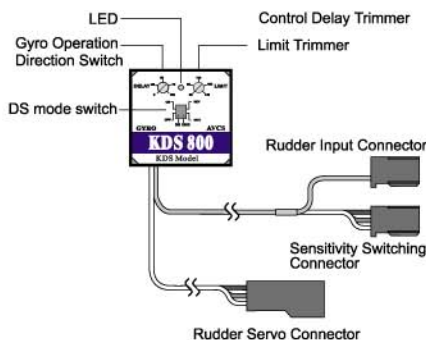

LED display:

LED display	Gyro operation state
Rapid flash	Indicate that data is being initialized after you turn on the power.
Steady light	Indicate that the gyro is operating in the AVCS mode.
OFF	Indicate that the power is OFF, or the gyro is operating in the normal mode.
slow flash	Indicate that gyro has not received any signal of rudder operation from the transmitter, the rudder servo cannot operate at this time..
Intermittent flash	Indicate that open power in the normal mode, but gyro can't initialize the data correctly at that time. Please switch the gyro sensitivity switch to the AVCS mode, and close the power of transmitter, then open it again. When in AVCS mode, rudder control signal currently received is different from neutral signal in the gyro.
Double flash	It happens in the following circumstances: The rudder stick is operating. The neutral position of tail rudder is moving, and you have to readjust and set it.

Explanation for parts name and fuctions:

Commodity name	Functions explanation
DS mode switch	Digital servo mode switch. When using a digital servo, please set the switch to the ON position. While using the normal one, set it to the OFF position. If it is set to the ON position, the servo will be destroyed.
Gyro Operation Direction Switch	Switch control direction of the gyro. It must be switched correctly according to the rotation direction of the main rotor on the helicopter and the direction of the rudder linkage.
Control Delay Trimmer	Adjust operation speed of rudder control signal. If using slower speed rudder, please turn the knob clockwise to increase delay time, then you can stop tracing. If using high-speed digital servo, please turn the knob anticlockwise to the position of "0".
Limit Trimmer	Adjust operation speed of rudder control signal. If using slower speed rudder, please turn the knob clockwise to increase delay time, then you can stop tracing. If using high-speed digital servo, please turn the knob anticlockwise to the position of "0".
Rudder Input Connector	Connect to the receiver rudder channel(CH4).
Sensitivity Switching Connector	Connect to the receiver sensitivity switching channel(normally CH5). This connector can be simultaneously used to switch the sensitivity of gyro between the AVCS and normal modes. Since this connector is a single wire signal line, do not pull it forcefully.
Rudder Servo Connector	Connect to the rudder servo.

KDS800 Installation on helicopter:

When installing the KDS800 on helicopter, please use the double-sided sponge tape included. Make sure the bottom of gyro is perpendicular to the main shaft of helicopter. Otherwise it will effect the direction in roll and pitch.

When installing KDS800 to electric helicopter, please make the distance to motor not less than 10cm to avoid interference.

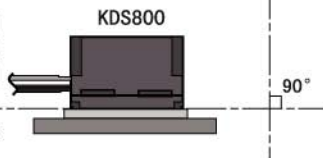

GYRO CONNECTION:

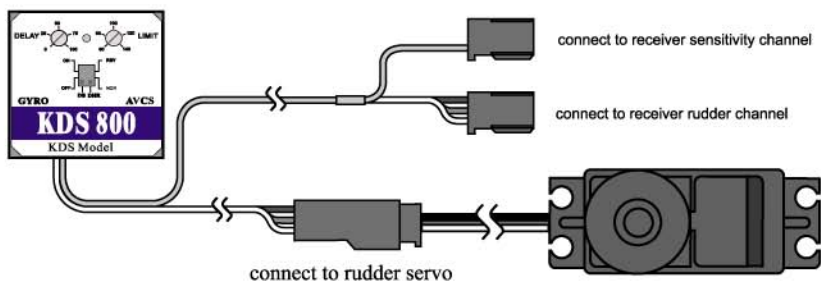

Servo selection:

Head lock function of gyro has close relations with the function of tail servo you use, the effect can be more prominent to use digital servo, It's recommended that you use futaba 9257 9650 digital servo etc. When using a digital servo as the tail servo, such as S9253 S9250 S9450, please set the DS mode switch to the ON position. While using a normal one, please set it to the OFF position.

NOTE: If using a normal servo, set the DS switch to the ON position instead, the rudder may be destroyed.

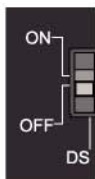

Check Gyro operation direction:

Lift the helicopter, vibrate its head to the left. (If the tail servo moves to the left when the tail servo linkage rod of the transmitter moves to the same direction, the gyro direction is correct.) If the direction is not correct, please switch the direction switch.

If operation direction of gyro is designed wrong, danger of high-speed rotation will arise while helicopter begins to fly. Please make sure gyro operation direction is correct again and again.

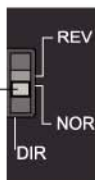

Adjust maximum travel of tail rudder servo:

Move the rudder stick to the left and right, and adjust the limit trimmer so that the servo operating angle does not strike the linkage. During flight, the servo will not operate beyond this limit and the linkage will be protected. If the setting is too low, the gyro performance will be affected.

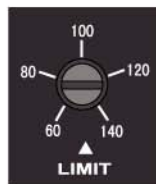

AVCS mode adjustment:



If using digital servo, please set delay time trimmer to the position of "0", while using normal servo, please adjust the delay volume according to the detailed fact.